

# DH-PFB120W

## Wall Mount Bracket



### Features

- Material: Aluminum
- Wall Mount Bracket
- Neat & Integrated design

### Specifications

Model	DH-PFB120W
<b>General</b>	
Material	Aluminum
Dimension (W x H x D)	188.7mm(W) x 58mm(H) x 80mm(D)
Pipe Thread	N/A
Operating Temperature	-40°C ~60°C
Humidity	0~90% RH
Load Bearing	1.0Kg
Weight	0.38kg
Applicable Model	CA-F(E/F), CA-FW(D/H/J/K), HAC-HFW(B/D), HDC-HF3200, IPC-HF, IPC-HFW(D)

# DH-PFB120W

## Dimensions (mm)

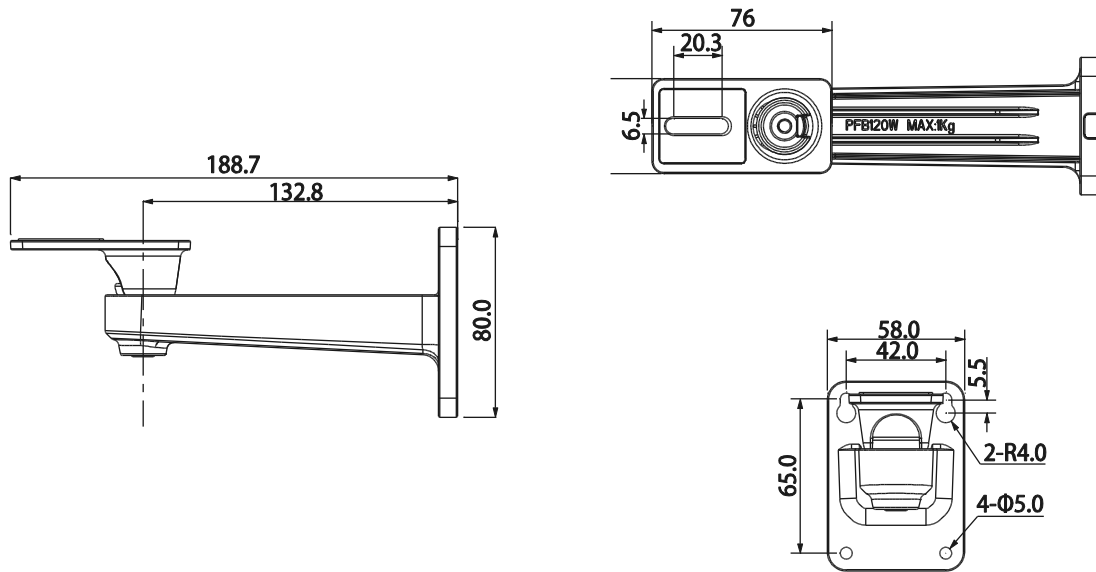

## Application

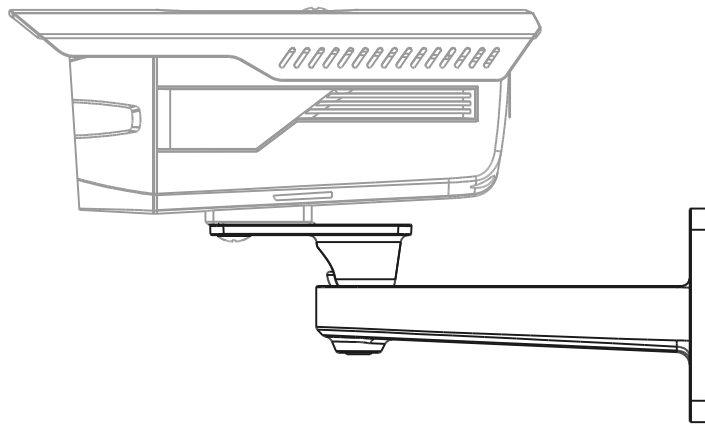

### Dahua Technology Co., Ltd.

1187 BinAn Road, Binjiang District, Hangzhou, China

Tel: +86-571-87688883

Fax: +86-571-87688815

Email: [overseas@dahuatech.com](mailto:overseas@dahuatech.com)

[www.dahuasecurity.com](http://www.dahuasecurity.com)

\*Design and specifications are subject to change without notice.

© 2013 Dahua Technology Co., Ltd.