

525DM: Microwave and Infrared Digital Anti-mask Motion Detector V2.4 P ▲ R ▲ D O X™

Description

The 525DM is a microwave and infrared digital motion detector featuring anti-masking detection. It features both a microwave sensor and a passive infrared sensor, and include's Paradox's powerful signal processing algorithms for triggering an anti-masking alarm when certain conditions occur.



With the anti-masking feature, the 525DM will detect attempts to blind the detector by placing objects in its field of view or spraying it with paint etc., enhancing the level of your site's security.

Installation

There are two mounting methods that can be used for the 525DM; corner mount and flat surface mount. To install the 525DM:

- 1) Select the detector's location. Avoid placing the detector in proximity to the following sources of interference: reflective surfaces, direct air flow, sources of steam/oil vapor, infrared light sources and objects causing temperature changes. Digital microwave detection will be hampered if installed close to vibrating metal surfaces, rotating fans, water flow in plumbing pipes or electromagnetic sources. Also note, microwave frequencies can penetrate walls, therefore, avoid installing the unit where it can respond to motion on the other side of the protected area's walls. Using a Paradox standard lens at the recommended installation height of 2.1m (7ft) ±10%, the 525DM detector will provide full coverage from 1.5m (5ft) to 12m (40ft) without any dead zones (see Figure 1: *Beam Pattern*).
- 2) Remove the front cover screw holding the cover in place; open the cover.
- 3) Loosen the screw holding the PCB in place and gently slide and lift from back cover.
- 4) Drill or punch out the selected knockout holes from the 525DM back cover (as shown in Figure 2: *Installation*) and mount the back cover using the appropriate screws.
- 5) Wire the unit as shown in Figure 3: *PCB Connection*.
- 6) Perform a walk-test to verify detector coverage (see *Walk-testing*).

WARNING: Do not touch the sensor surface as this could result in a detector malfunction. If necessary, clean the sensor surface using a soft cloth with pure alcohol.

Features

- Digital microwave/infrared detection
- Anti-mask feature allows for the detection of close proximity movements (less than 0.75m / 2.5ft) within the detector range
- Adjustable microwave range
- Two auto pulse settings; one for typical environment (normal), and one for high false alarm rejection (high)
- Installer Test Mode: test microwave and infrared detection individually
- 12m (40ft) X 12m (40ft); 90° viewing angle

Figure 1: Beam Pattern

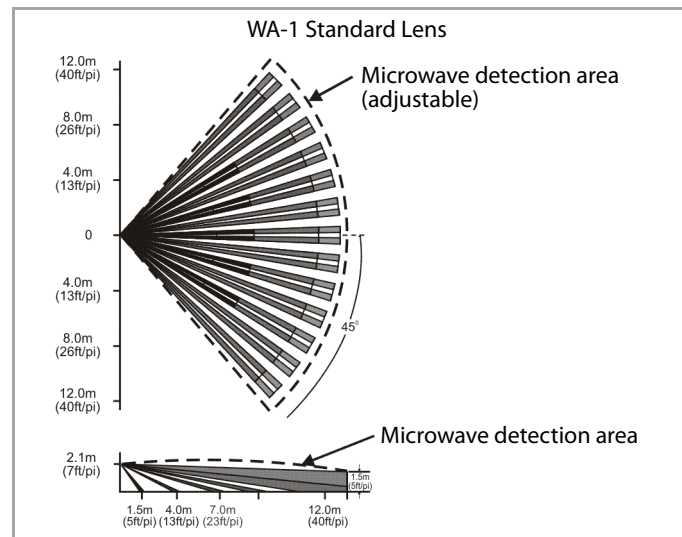

Figure 2: Installation

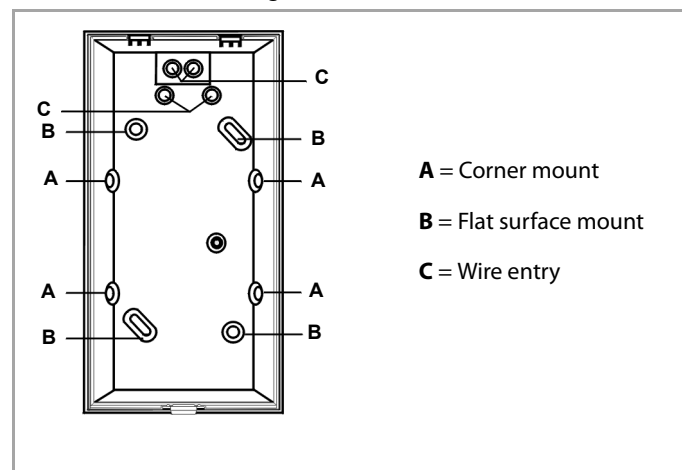
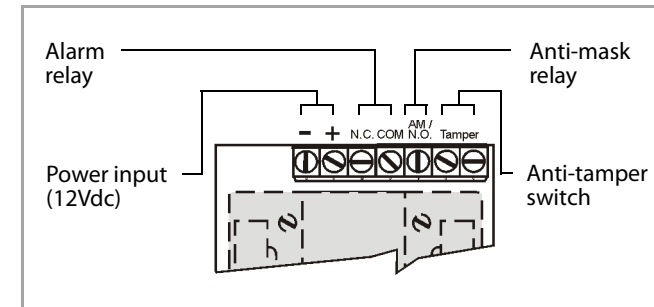

Figure 3: PCB Connection



Turning on the 525DM

Turning on the detector initiates a self-testing program for the signal processor and memory. The LEDs will flash for 16 seconds. When the LEDs are no longer flashing, the detector is ready and fully operational.

Walk-testing

At 20°C (68°F), at the highest sensitivity level, with APSP set to *normal*, and in dual-edge processing mode, you should be detected crossing at least one complete zone (consisting of 2 beams, left and right sensor detecting elements) in the coverage area with any kind of movement; slow/normal walking or running.

With APSP set to *high*, the amount of movement required to generate an alarm is doubled, and you should be detected within crossing 2 complete zones. The approximate width of a full beam at 12m (40ft) from the detector is 1.8m (6ft). To walk-test, move across the detection path, not toward the detector.

Anti-mask Detection Details

Anti-masking is active only if a valid movement detection occurred during the 10 minutes prior to the anti-mask detection. When a moving object gets near the detector, the blue LED starts flashing for 90 seconds (AM relay not activated yet). If an alarm occurs during that period, the LED stops flashing and no anti-mask trouble occurs. If no alarm occurs within that 90 seconds, anti-mask trouble occurs – AM relay is activated and the LED turns steady blue ON. The anti-mask trouble is cleared by an alarm event.

Relay Operation Details

When anti-masking is enabled, both the alarm and anti-mask relay are independent. When anti-masking is disabled, both relays are activated by an alarm, where the anti-mask relay functions as N.O., and the alarm relay functions as N.C. In *Installer Test Mode* (see reverse page), the alarm relay is continuously activated, and the anti-mask relay is activated upon an alarm. For connection details, see Figure 4: *AM Relay Output Connection*.

Figure 4: AM Relay Output Connection

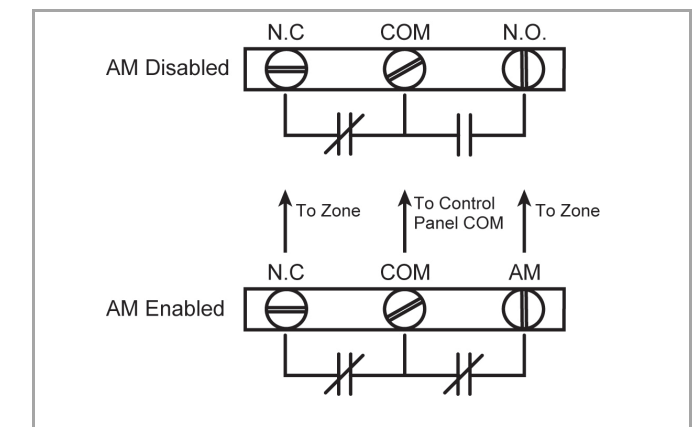

LED Indicator (Normal Operation)

LED State	Description
Red - 4 seconds	Alarm (movement detection)
Blue - Flashing 90 sec.	Anti-mask detection pending*
Blue - ON	Anti-mask detection*
Green - 0.5 seconds	Microwave detection
Yellow - 0.5 seconds	Infrared detection

*See Anti-mask Detection Details for more information.

LED Indicator (Installer Test Mode)

LED State	Description
Yellow - 4 seconds	Infrared detection
Green - 4 seconds	Microwave detection

Detector Settings

The following detector settings can be modified using the unit's DIP switches (see Figure 5: Overview). Any changes that are made to DIP switch settings are ignored during a movement alarm or an anti-mask detection. To ensure that new DIP switch settings have been registered, ensure that the unit is not in anti-mask alarm, then move out of the unit's detection path and wait for the LED to turn OFF.

Step	DIP / Trimpot	Details
1 Operational Mode		The 525DM uses both infrared and microwave detection. Setting DIP switch 1 to OFF will allow you to test each detection method individually. This feature is used in conjunction with DIP switch 3 Installer Test Mode
	DIP Switch 1	DIP switch 1 OFF = installer test mode (see step 3) DIP switch 1 ON = operational mode Δ
2 LED Settings		If DIP switch 2 is turned ON, the LED will indicate detections as per the <i>LED Indicator</i> table.
	DIP Switch 2	DIP switch 2 OFF = LED disabled DIP switch 2 ON = LED enabled Δ
3 Anti-Mask		When DIP switch 3 is turned ON, the anti-mask feature will detect close proximity movements (less than 0.75m / 2.5ft) within the detector range. NOTE: For the anti-mask feature to be enabled, DIP switch 1 must be ON.
	DIP Switch 3	DIP switch 3 OFF = anti-mask disabled DIP switch 3 ON = anti-mask enabled Δ
Installer Test Mode		DIP switch 3 OFF = test infrared only DIP switch 3 ON = test microwave only For test mode LED feedback, see LED Indicator (Installer Test Mode). NOTE: In installer test mode, relay functions and anti-mask are deactivated or altered.
	DIP Switch 3 (with DIP1 OFF)	
4 Edge Processing Mode		Preferably, dual edge processing should be used at all times. Dual edge processing requires balanced detection from both sensor's elements and requires that a beam must be fully crossed even at close range. This setting provides better false alarm rejection. Single edge setting allows for faster detection of close range movements. Use this setting only in normal environments with minimal sources of interference. Never use single edge setting if the detector is placed near sources of interference that could adversely affect it.
	DIP Switch 4	DIP switch 4 OFF = single edge DIP switch 4 ON = dual edge Δ
5 Auto Pulse Signal Processing Level		APSP measures the energy from each detected signal and stores it in memory. To generate an alarm, the memory must reach a required minimum level. APSP can be set to <i>normal level</i> or <i>high level</i> . When APSP is set to <i>normal level</i> , the unit is calibrated to detect the energy level which is typical to crossing one full single beam at the maximum detection distance. When APSP is set to <i>high level</i> , the unit is calibrated to detect the energy level which is typical to crossing two full beams at the maximum detection distance. Set APSP to <i>high level</i> when the detector is installed in high-risk environments (potential interference) and to provide greatly increased false alarm immunity.
	DIP Switch 5	DIP switch 5 OFF = APSP - normal level Δ DIP switch 5 ON = APSP - high level
8 Microwave Range Trimpot		Microwaves generated by the unit can pass through walls and have the potential to interfere with the performance of other 525DM units. The range of the microwaves emitted by the detector can be adjusted using the trimpot (see Figure 5: Figure 5: Overview). Microwave trimpot adjustment can be verified using <i>microwave only</i> test mode.
	Trimpot	Turn clockwise = increase microwave range Turn counterclockwise = decrease microwave range WARNING: The trimpot is fragile. Do not overtorque.

Δ= default settings

Figure 5: Overview

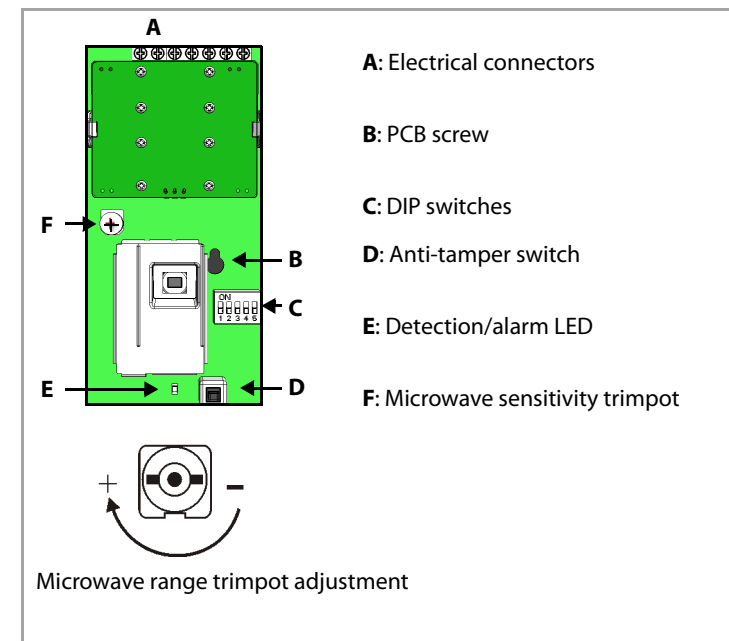

Technical Specifications

Motion detector type	PIR + Microwave
PIR sensor element type	Dual elements
PIR sensor geometry	Rectangular
Range (90° standard lens)	12m x 12m (40ft x 40ft)
Microwave antenna type	Flat strip microwave antenna with FET oscillator
Frequency	FCC & DOC - 10.525GHZ (other frequencies available)
Operating temperature	-20° to +50°C (-4° to +122°F)
Voltage	10 - 16Vdc
Current consumption	30mA (approximately)
Alarm form A output	Standard 100mA, 28Vdc
Alarm solid-state output	N.C. 150mA, 28Vdc (optional)
Tamper form C output	N.C. 150mA, 28Vdc (optional)
Alarm period	4 seconds
Detection speed	0.2m to 3.5m/s (0.6ft to 11.5ft/s)

Warranty

© 2011 Paradox Ltd. All rights reserved. Specifications may change without prior notice. One or more of the following US patents may apply: 7046142, 6215399, 6111256, 6104319, 5920259, 5886632, and RE39406 and other pending patents may apply. Canadian and international patents may also apply. LODIFF® lens: patent #4,787,722 (U.S.). Digital Vision is a trademark or registered trademark of Paradox Ltd. or its affiliates in Canada, the United States and/or other countries. LODIFF® is a registered trademark of Fresnel Technologies Inc. For the latest information on products approvals, such as UL and CE, please visit www.paradox.com. **Warranty:** For complete warranty information on this product please refer to the Limited Warranty Statement found on the website www.paradox.com/terms. Your use of the Paradox product signifies your acceptance of all warranty terms and conditions.